

ELITE COMPONENTS



ADDICTIVE AUDIO

ECS5 / ECS6

90 rms - 200 max / 95 rms - 210 max
90.3dB 1w/1m / 90.4dB 1w/1m

Freq. Response

50Hz - 22-25kHz / 45Hz - 22-25kHz

www.ADDICTIVEAUDIOINC.com

WOOFER

BUTYL RUBBER SURROUND

WOVEN BLACK KEVLAR CONE

4ohm 1" KAPTON³ VOICE COIL

SYMMETRICAL ROLL NC SPIDER

RIGID CAST ALUMINUM BASKET

15oz. STRONTIUM FERRITE MOTOR

MAGNET COVER

MESH GRILL

TWEETER - CHOICE OF:

.75" PURE SILK MEMBRANE (ECST20S)

OR

.75" SILK INFUSED ALUMINUM MEMBRANE (ECST20A)

NEODYMIUM MOTOR AND FERROFLUID COOLED

CROSSOVER

METALIZED POLYPROPYLENE (1% TOL.) CAPACITORS

AIR AND IRON CORE INDUCTORS

LIGHT ATTENUATED TWEETER CIRCUIT

SECOND ORDER 6dB CROSSOVER FOR WOOFER

SECOND ORDER 12 dB CROSSOVER FOR TWEETER

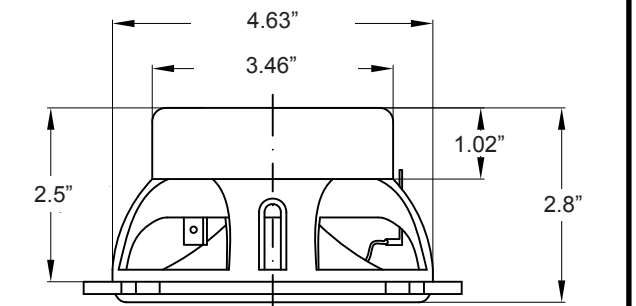
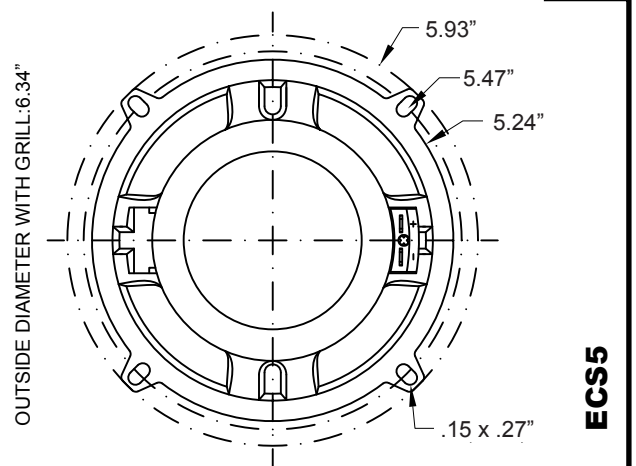
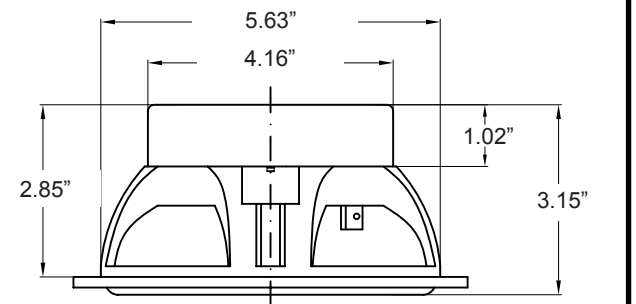
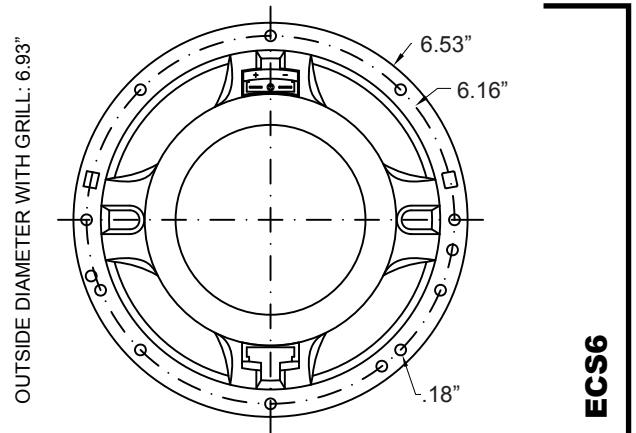
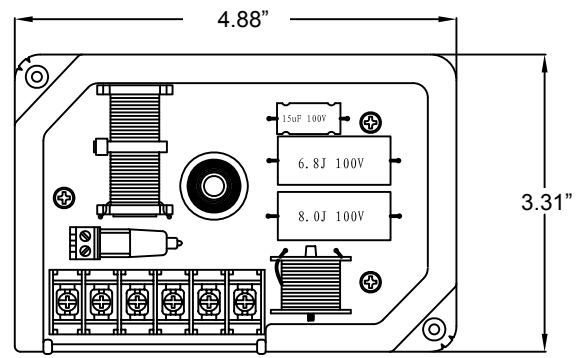

ECS5/ECS6 INSTALLATION INSTRUCTIONS

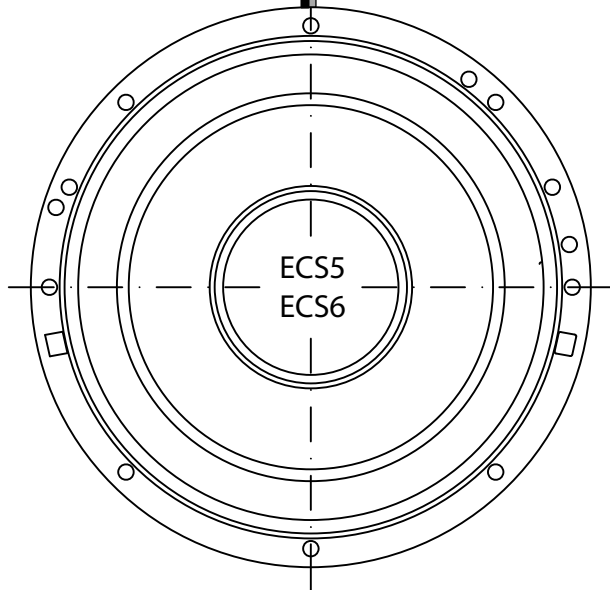
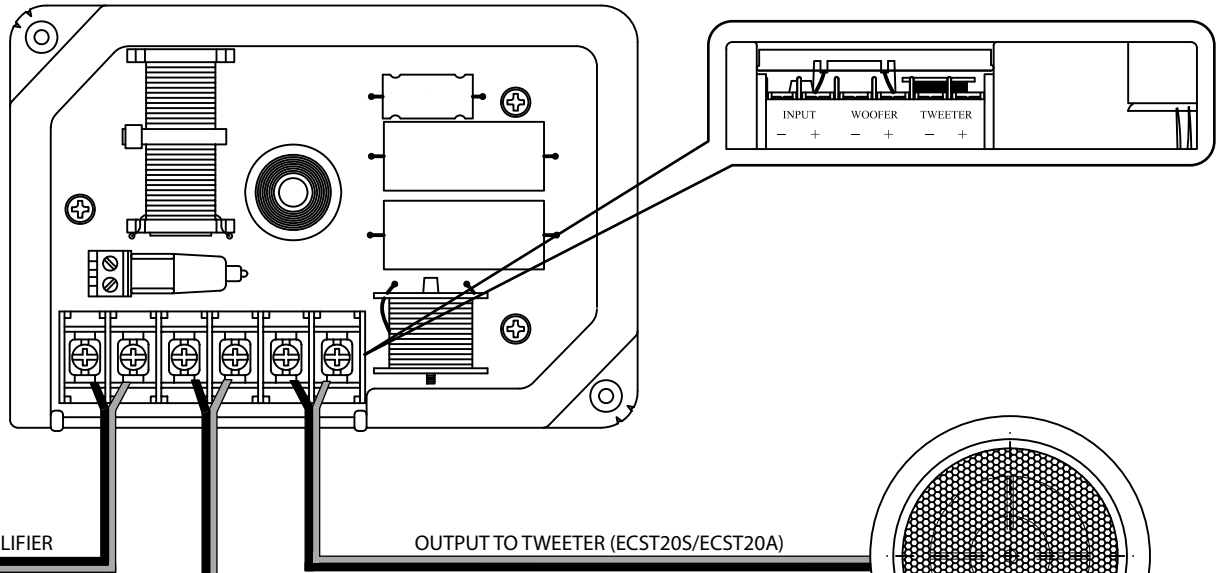

ECS5/ECS6 CRITICAL NOTES

1. When installing an ECS5/ECS6 be sure to remove the crossover that is already connected to the tweeter for models ECST20S and ECST20A.

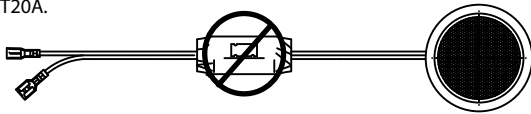

2. In the event the light attenuation bulb burns out in the crossover, be sure to replace with identical bulb.

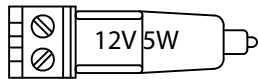

3. Power handling remains the same whether you use ECST20S or ECST20A

LIMITED WARRANTY INFORMATION

Addictive Audio warrants this product to be free from defects in material and workmanship under normal use for a period of one (1) year from date of original purchase when installed by an authorized dealer. Items not installed by an authorized dealer will be warrantied for ninety (90) days from date of original purchase. All returns must be accompanied with original sales receipt. Should service be necessary under this warranty for any reason due to manufacturing defect or malfunction during the warranty period, Addictive Audio will replace or repair (at its discretion) the defective merchandise with equivalent merchandise at no charge. Discontinued products may be replaced with equivalent products. This warranty is valid only for the original purchaser and is not extended to owners of the product subsequent to the original purchaser. Any applicable implied warranties are limited in duration to a period of the express warranty as provided herein beginning with the date of original purchase at retail, and no warranties, whether express or implied, shall apply to this product thereafter. Some states do not allow limitations on implied warranties, therefore these exclusions may not apply to you.

THE FOLLOWING IS NOT COVERED BY WARRANTY

- This warranty is valid only if the product is used for the purpose for which it was designed. It does not cover:
- Damage to cone, dustcap, or surround due to installation slips.
 - Speakers with silicon caulk used for gasket material.
 - Speakers damaged due to amplifier clipping or distortion.
 - Damage caused by exposure to water and/or excessive heat.
 - Damage through negligence, misuse, or accident.
 - Items physically damaged due to abuse.
 - Freight damage.
 - The cost of shipping product to Addictive Audio Service Center.
 - Items previously repaired by any unauthorized individuals or dealers.
 - Items returned from unauthorized individuals or dealers.
 - Items returned without original sales receipt.
 - Return shipping on non-defective items.

WHAT TO DO IF YOU NEED WARRANTY OR SERVICE

- Please follow each step below completely. Warranty or service will not be honored unless each and every step below is completed.
- 1. Obtain an Return Authorization Number**
 - Go to www.addictive-audio.com and click "SUPPORT" then click "OBTAIN R.A.#"
 - Call Addictive Audio Customer Service at (559) 348-9550 (Mon-Sat 10am-5pm P.S.T.).
 - 2. Pack items in original container(s) or in a package that will prevent shipping damage.**
 - Original sales receipt from Authorized Dealer must be included for each item returned.
 - 3. The RA# should be clearly marked on outside of the package. Return only defective components.**
 - 4. Freight must be prepaid; items received freight collect will be refused.**

After completing all 4 steps above, please send package to:
Addictive Audio - 2686 N. Clovis Ave. #102 - Fresno, CA 93727
 Failure to complete any one of the steps above when obtaining warranty/service may void your warranty.